

# 2023 Product Catalog

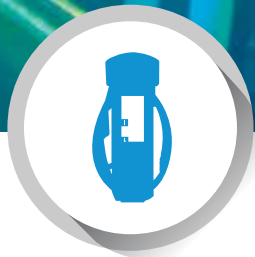

**Dryers**



**Vacuums**



**LED Lighting**



**Signage**



Your Manufacturing Partner



## Dryers page 4

ARCH DRYERS.....	4
EXTERIOR WALL MOUNT DRYERS.....	6
INTERIOR WALL MOUNT DRYERS.....	7
TUNNEL DRYERS .....	8
PRODUCERS.....	9
OSCILLATING OPTIONS.....	10
EVOLUTION SERIES.....	11
UL® LISTED VFD & STARTER PANELS .....	14
PALM DRYERS.....	15



## Vacuums page 16

SILVER BULLET .....	16
STAINLESS STEEL VACS .....	17
STAINLESS STEEL CANOPY VACS .....	18





# Who We Are

We are a family owned, industry-leading company, offering complete metal fabrication, finishing services and products.

Premier Companies has its own product line that supplies the car wash, and many other industries with Dryers, Vacuums, Signage, LED Lighting and Canopy Stations. All of our products are proudly designed and manufactured in Central Wisconsin.

# What We Do

The selection of products manufactured by Premier Companies are not only of the highest quality, but are also available in a variety of options to ensure you find exactly what you're looking for. With top-of-the-line materials, cutting-edge production technologies and a highly qualified team, we guarantee complete satisfaction.



## LED Lighting page 20

COLOR CHANGING LED TUBE LIGHTING.....	20
--	----



## Signage page 22

ARCHES & OVERHEADS .....	22
MENU & MENU BOARDS .....	25
PAY STATION CANOPIES .....	26
PEDESTALS & WALL MOUNT .....	27
ROTO-MOLDED SIGNS .....	27
TUNNEL/WALL & CHANNEL LETTERS .....	27
CLEARANCE .....	27
TUNNEL/WALL & CHANNEL LETTERS .....	27



Premier manufactures custom drying equipment for many industries all over the world. Many hours and years of experience studying air flow and air distribution have made our dryers number one on the market.

At Premier, our customers are our partners. We provide our customers with individualized solutions to maximize functionality for the perfect dryer system set up. Not only does Premier provide great products and service, we also lead in price, custom design, private labeling and dryer performance. Our positive and knowledgeable staff are ready and available to make your venture a profitable and enjoyable experience.

# Floor Mounted Arch Dryers



ARCHES ARE AVAILABLE IN ALUMINUM

9' Maximum  
8'6" Minimum

35" - 40"



- Arches available in aluminum or stainless steel:



- Standard dryer clearance is 90", but is fully customizable to any specs desired
- HDPE producer housing colors available:





MOTORS AVAILABLE  
IN 5HP, 7.5HP, 10HP  
OR 15HP

ARCHES ARE  
AVAILABLE  
IN STAINLESS  
STEEL

MANY NOZZLE  
OPTIONS ARE  
AVAILABLE  
*page 9*

## Common Arch Configurations

Additional and customizable configurations are available. Please contact us.

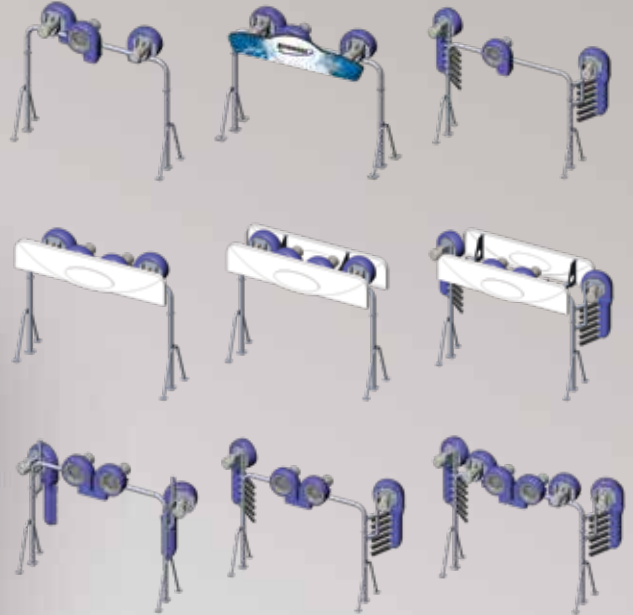

## Arch Dimensions

Standard dryer clearance is 90", but is fully customizable to any specs desired.

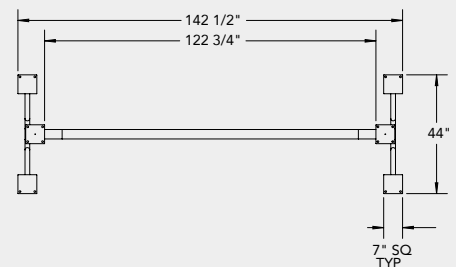
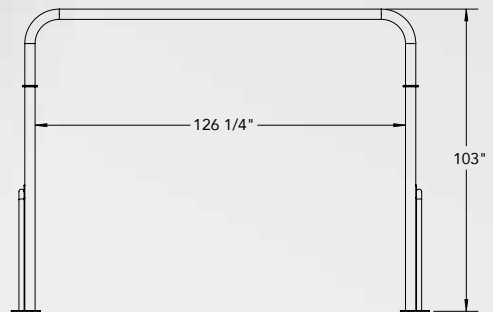





SEVERAL PRODUCER HOUSING COLORS ARE AVAILABLE

# Exterior Wall Mount Dryers

- Aluminum and stainless steel available

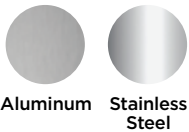

Aluminum Stainless Steel

- HDPE producer housing colors available:

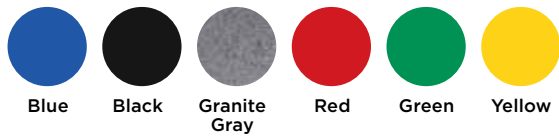

Blue Black Granite Gray Red Green Yellow

- Standard powder coat colors are:

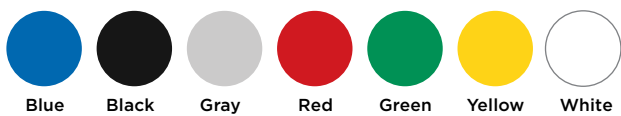

Blue Black Gray Red Green Yellow White

- Custom powder coat colors available by request

## Common Exterior Dryer Configurations

Additional and customizable configurations are available. Please contact us.

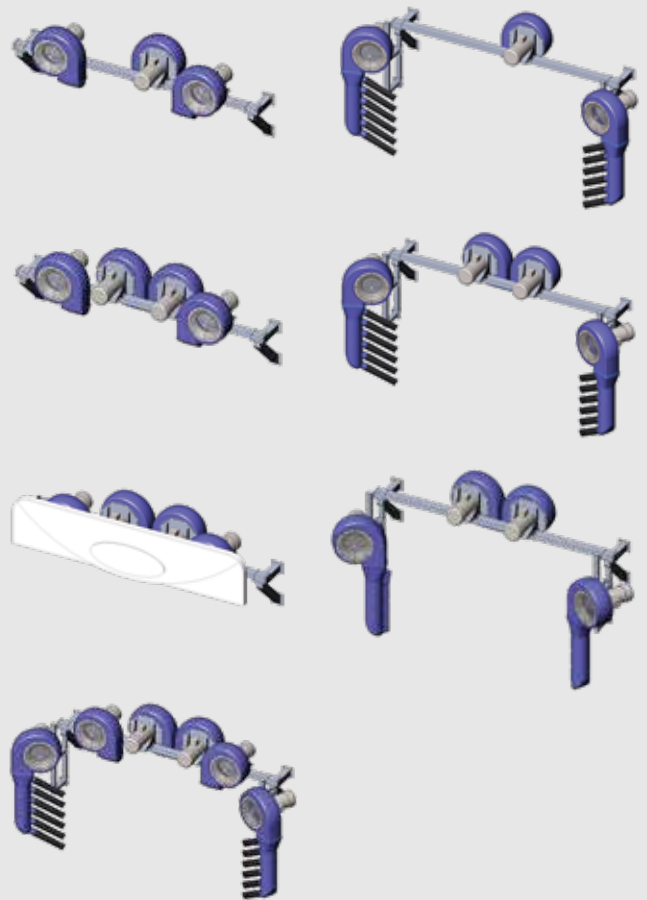



VARIOUS  
POWDER COAT  
COLORS ARE  
AVAILABLE

## Interior Wall Mount Dryers



### Common Interior Dryer Configurations

Additional and customizable configurations are available. Please contact us.

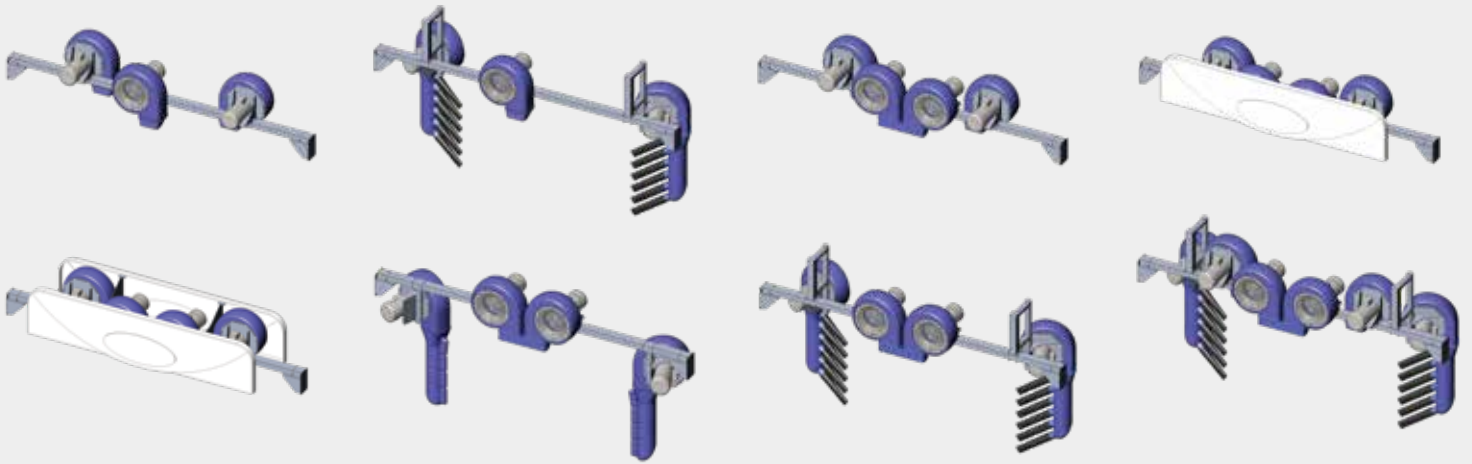





MOTORS  
AVAILABLE  
IN 5HP, 7.5HP,  
10HP OR 15HP

# Tunnel Dryer Applications

## Common Tunnel Configurations

Additional and customizable configurations are available. Please contact us.

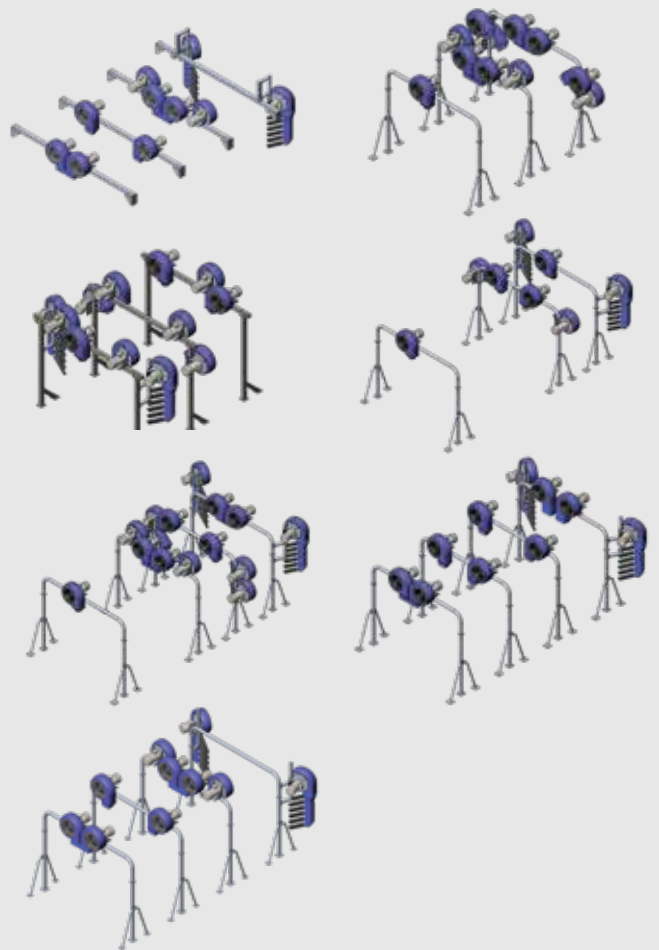





## Producers



- HDPE producer housing colors available:



- Fiberglass cover with custom graphics available
- LED backlit cover with custom graphics available
- UL Listed VFD and standard starter panels available
- LED lighting available
- Custom applications available
- 5 HP available upon request

### Producer Specifications

	7.5 HP Producer	10 HP Producer	15 HP Producer
<b>208 V Fla</b>	18.6 amps	24.9 amps	36.2 amps
<b>230 V Fla</b>	17.0 amps	22.5 amps	32.8 amps
<b>460 V Fla</b>	8.5 amps	11.2 amps	16.4 amps
<b>SF amps</b>	1.3	1.25/40	1.25/40
<b>CFMs</b>	3525	4200	4500
<b>RPM</b>	3525/60 Hz	3490/60 Hz	3500/60 Hz
<b>Air Velocity</b>	120 mph	135 mph	142 mph
<b>TEFC Motors</b>	3 Phase	3 Phase	3 Phase
<b>Frame Size</b>	215 Tc	215 Tc	215 Tc
<b>Total Weight</b>	220 lbs	230 lbs	230 lbs

*Efficiency Level - (Minimum), 88.5% guaranteed efficiency, Nema NCM efficiency (Normal) 90.2%*

### Producer Nozzle Options

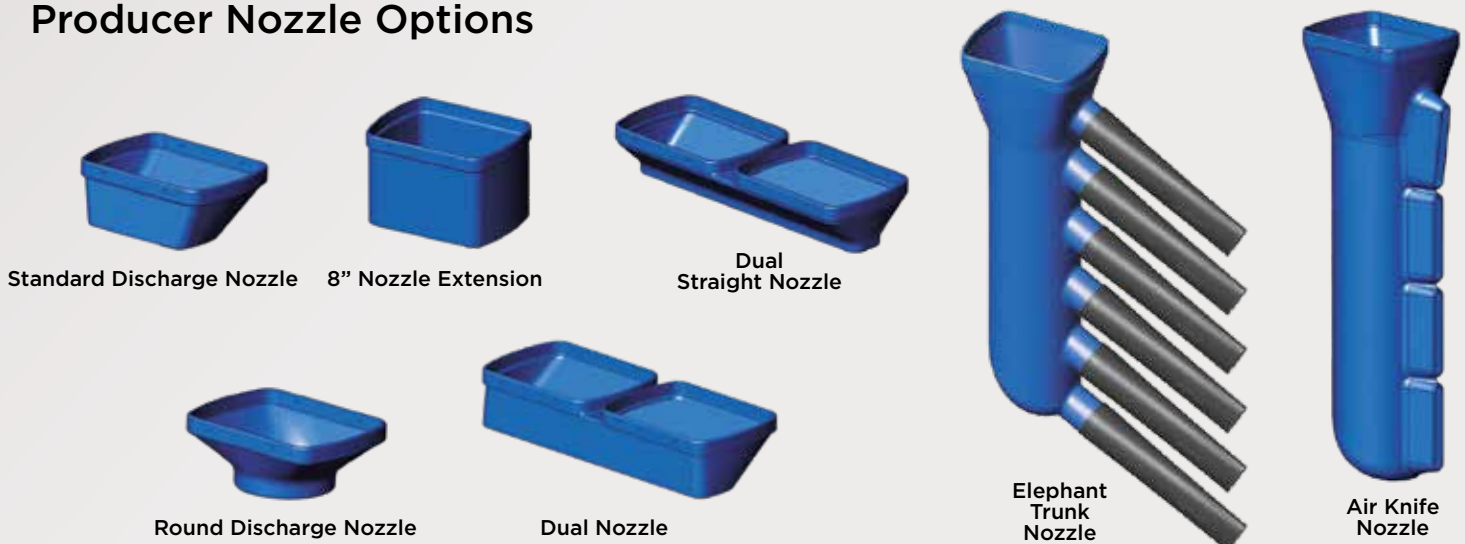

# Oscillating Options

## Motor Driven Oscillating Producers

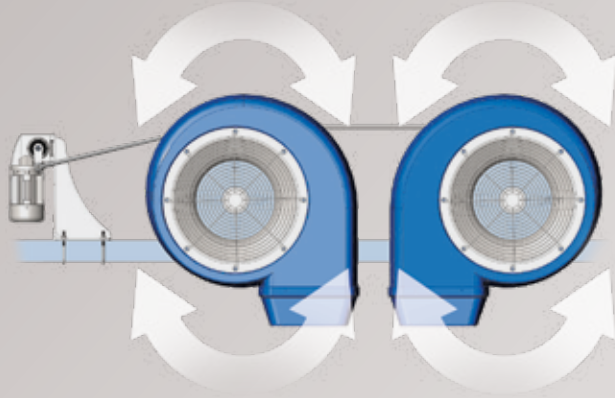

**Dual Oscillator**

0.25 HP 3ph Gear Motor • Approximately 30° Swing

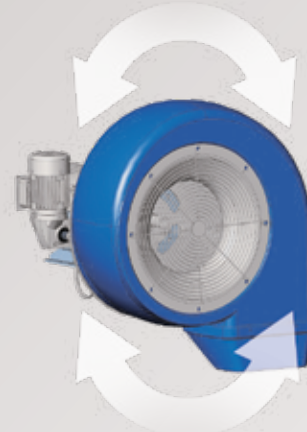

**Single Oscillator**

0.25 HP 3ph Gear Motor • Approximately 30° Swing

## Air Driven Oscillating Nozzles



**Single Oscillating Nozzle**

2X Oscillating Blades  
Approximately 30° Swing



**Dual Oscillating Nozzle**

4X Oscillating Blades  
Approximately 30° Swing



**Flip Nozzle**

Air Outlet Direction Flips Forward to Reverse as Vehicle Passes

## How Loud Are Our Producers?

### Inside Door Closed

Distance From Bay	90 HP (6 - 15 HP)	60 HP (4 - 15 HP)	45 HP (3 - 15 HP)	10 HP (1 - 10 HP)
10 ft	102 dB	101 dB	100 dB	94 dB
20 ft	100 dB	99 dB	98 dB	92 dB
30 ft	98 dB	98 dB	98 dB	91 dB

### Outside Door Open

Distance From Bay	90 HP (6 - 15 HP)	60 HP (4 - 15 HP)	45 HP (3 - 15 HP)	10 HP (1 - 10 HP)
10 ft	98 dB	95 dB	96 dB	90 dB
20 ft	92 dB	90 dB	89 dB	84 dB
30 ft	88 dB	86 dB	85 dB	79 dB
40 ft	84 dB	82 dB	82 dB	76 dB
50 ft	80 dB	80 dB	79 dB	74 dB

Decibel levels may drop 4 to 5 dB's or more with full cover surrounds or silencer cones. Readings may vary. Readings were conducted with Premier Plastic Housings.

## Decibel Scale

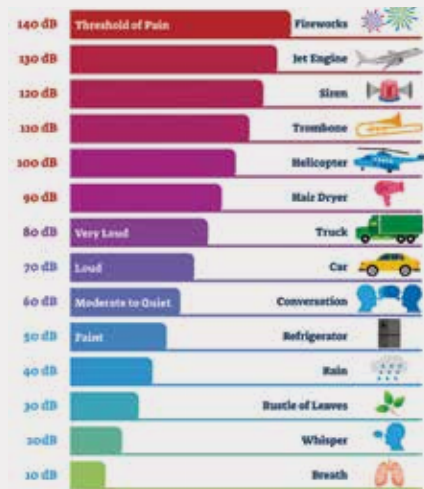





## Introducing the New **Evolution Series**

Oscillating | Flip | Extending

# Evolution Series Oscillating Nozzle

### Oscillating Nozzle

- Swings left and right approximately 30 degrees
- Pneumatic or electric actuation
- Available in single or dual configurations

- HDPE producer housing colors available:
 

Blue	Black	Granite Gray	Red	Green	Yellow
- Fiberglass cover with custom graphics available
- LED backlit cover with custom graphics available
- UL Listed VFD and standard starter panels available
- LED lighting available
- Custom applications available
- 5 HP available upon request

# Evolution Series Extending Nozzle

### Extending Nozzle

- Cylinder extends nozzle up to 12" to follow the vehicle contour
- Retracted position offers the same clearance as our standard producers

Dimensions shown in diagram:

- Retracted height: 28 1/8"
- Retracted width: 17 5/8"
- Extended height: 28 5/8"
- Extended width: 48 3/4"
- Stroke length: 5 5/8"
- Top offset: 8 7/8"





## Evolution Series Flip Nozzle

### Flip Nozzle

- Swings approximately 15 degrees in both forward and backward directions
- Pneumatic or electric actuation
- Available in left, right, or dual configurations

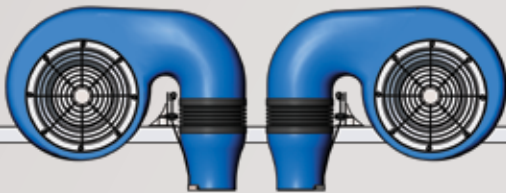
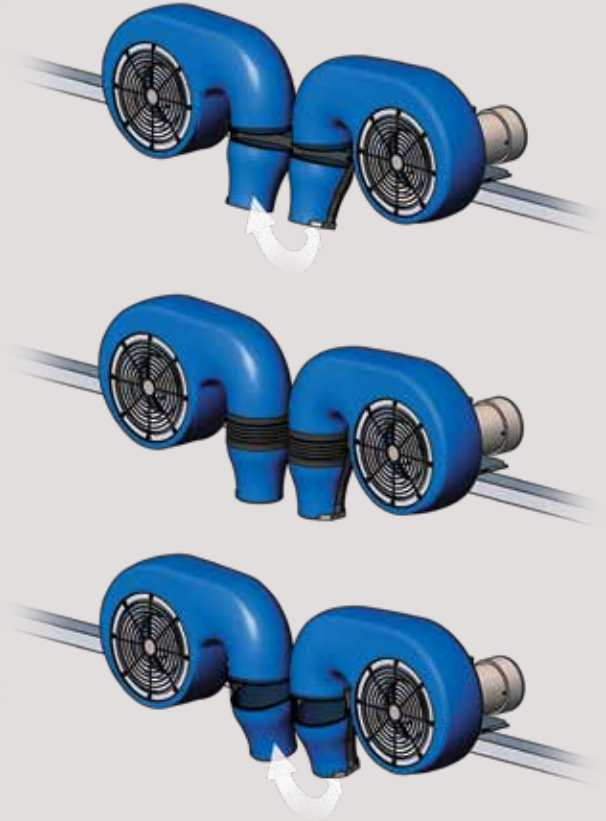

### Fixed Nozzle Adapter

- May be used as a standalone nozzle, or as an adapter for air knives and e-trunks
- Allows an e-trunk or air knife to be adjusted 360 degrees



### Producer Specifications

	7.5 HP Producer	10 HP Producer	15 HP Producer
<b>208 V Fla</b>	18.6 amps	24.9 amps	36.2 amps
<b>230 V Fla</b>	17.0 amps	22.5 amps	32.8 amps
<b>460 V Fla</b>	8.5 amps	11.2 amps	16.4 amps
<b>SF amps</b>	1.3	1.25/40	1.25/40
<b>CFMs</b>	3525	4200	4500
<b>RPM</b>	3525/60 Hz	3490/60 Hz	3500/60 Hz
<b>Air Velocity</b>	120 mph	135 mph	142 mph
<b>TEFC Motors</b>	3 Phase	3 Phase	3 Phase
<b>Frame Size</b>	215 Tc	215 Tc	215 Tc
<b>Total Weight</b>	220 lbs	230 lbs	230 lbs

Efficiency Level - (Minimum), 88.5% guaranteed efficiency, Nema NCM efficiency (Normal) 90.2%



SAVE ENERGY AND MONEY WITH OUR VFD PANELS!

# UL LISTED VFD and Starter Panels

## Features and Benefits

- Yaskawa VFDs (world leading VFD manufacturer)
- Arrives pre-programmed to your specific needs
- User-friendly with 24/7 technical support
- Energy rebates may be available in your area
- Energy savings from avoiding start up current
- Eco friendly
- No mechanical moving parts
- Unlimited performance options
- Extends parts and motor life
- Replaces existing starter panel
- Reduces noise levels
- Great return on investment
- Saves you money



USE YOUR PHONE'S CAMERA TO SCAN THE CODE

## Save Energy and Money

- At **58 hz**, owner saves **19%** on energy cost.\*
- At **57 hz**, owner saves **24%** on energy cost.\*
- At **55 hz**, owner saves **32%** on energy cost.\*

\* Data collected from 10 HP 208 volt during 60 second dryer time.

Watch our video to learn more about Premier VFD panels.







MANY HOSE AND  
DOME COLOR  
OPTIONS  
AVAILABLE

## Palm Dryers

- **110V AC**  
(3 Motor) 50 amp service  
(2 Motor) 30 amp service
- **240V AC**  
(3 Motor) 25 amp service  
(2 Motor) 20 amp service
- Relay: 110v, 24v or wired direct
- Available in attic mount, half wall pedestal mount or wall mount
- Available hose colors: red, blue, yellow, black and gray
- Available dome colors:



Blue



Black



Granite  
Gray



Red



Green



Yellow





### Silver Bullet

- Stainless steel cabinet
- Crevice tool
- Easy clean out door
- Single 120v motor
- Wire with another vacuum or toggle switch option
- Plastic domes available in:



Premier Vacs are equipped with newly designed high efficiency vacuum motors gaining 85% more performance with two motors, outperforming the competition's three motor and central vac systems.

Want even more performance? A third motor will not disappoint. The Premier Vac features a newly designed silencing system that makes it the quietest vacuum on the market today.

- Options include light poles with LED lights, post covers and mat holders
- Available hose colors: red, blue, yellow, black and gray
- Available standard and lit dome colors:







## Stainless Steel Vacs

**2 OR 3 MOTOR OPTIONS (220v motor upgrade available):**

2 - 120v motors with 2" hose: FLA = 25 amps, 223 CFM, 910 AirWatts

3 - 120v motors with 2" hose: FLA = 35 amps, 315 CFM, 1212 AirWatts



### Premier Express Vac

- 2 or 3 motor options (3 motor 35 FLA, 2 motor 25 FLA)
- 4-bag filter system
- 2 accessible back doors for easy clean out
- Tough upholstery tool with swivel cuff
- Added money box lock bar for security
- **Express 1** includes push button or toggle switch options
- **Express 2** offers multiple timer, coin, bill and credit card options
- **Express 3** features air and vacuum  
*(Not available with 3rd motor)*



### Premier Aroma Vac

- 2 or 3 120v motor options (3 motor 35 FLA, 2 motor 25 FLA)
- Dispenses 3 fragrances of your choice
- 4-bag filter system
- 2 accessible back doors for easy clean out
- Tough upholstery tool with swivel cuff
- Bright LED display timer with adjustable price per function
- Optional coin, bill or credit card acceptors



### Premier Executive Vac

- 2 or 3 120v motor options (3 motor 35 FLA, 2 motor 25 FLA)
- 4-bag filter system
- Dispenses shampoo and 3 fragrances of your choice
- 2 accessible back doors for easy clean out
- Tough upholstery tool with swivel cuff
- Bright LED display timer with adjustable price per function
- Can be set up to accept coins, bills and/or credit cards



### Premier Magic Vac

- 2 or 3 120v motor options (3 motor 35 FLA, 2 motor 25 FLA)
- Dispenses shampoo and spot remover
- 4-bag filter system
- 2 accessible back doors for easy clean out
- Tough upholstery tool with swivel cuff
- Bright LED display timer with adjustable price per function
- Multiple coin, bill and credit card acceptor options





# Stainless Steel Canopy Vacs

## 2 OR 3 MOTOR OPTIONS (220v motor upgrade available):

2 - 120v motors with 2" hose: FLA = 25 amps, 223 CFM, 910 AirWatts

3 - 120v motors with 2" hose: FLA = 35 amps, 315 CFM, 1212 AirWatts

### Vacuum Specs

- 4-bag filter system
- 2 accessible back doors for easy clean out
- Tough upholstery tool with swivel cuff
- Added money box lock bar for security
- **Express 1** includes push button or toggle switch options
- **Express 2** offers multiple timer, coin, bill and credit card options
- Powder coating available
- Other options include light poles with LED lights, post covers and mat holders
- Dome colors: 
- Hose colors: 
- Canopy colors: 
- Custom canopy colors available upon request



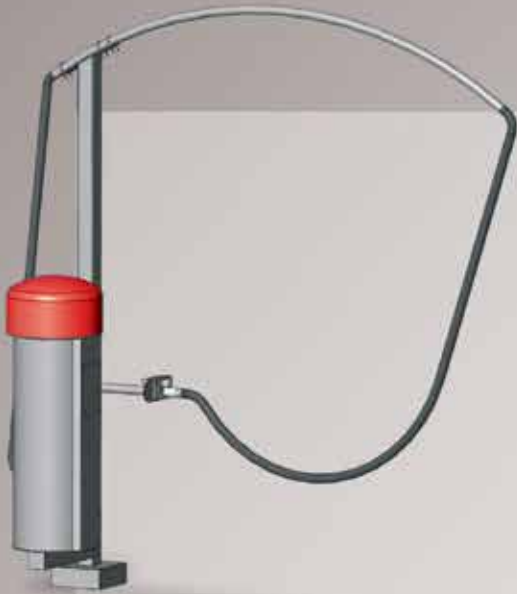

### Premier Express-1 Vac

- Single vac station with boom
- LED upgrades available
- Push button or toggle switch start



### Premier Single Express-2 Vac With Meter Box

- Single vac station with dual boom
- Canopy add-on for dual vac station
- Pedestal mounted nozzle holder
- LED upgrades available



### Premier Single Express-2 Vac With Meter Box

- Single vac station with dual boom
- Canopy add-on for dual vac station
- Garbage can add-on
- LED upgrades available



### Premier Dual Express-2 Vac With Individual Meter Boxes

- Dual vac station with dual boom
- Canopy add-on for dual vac station
- LED upgrades available



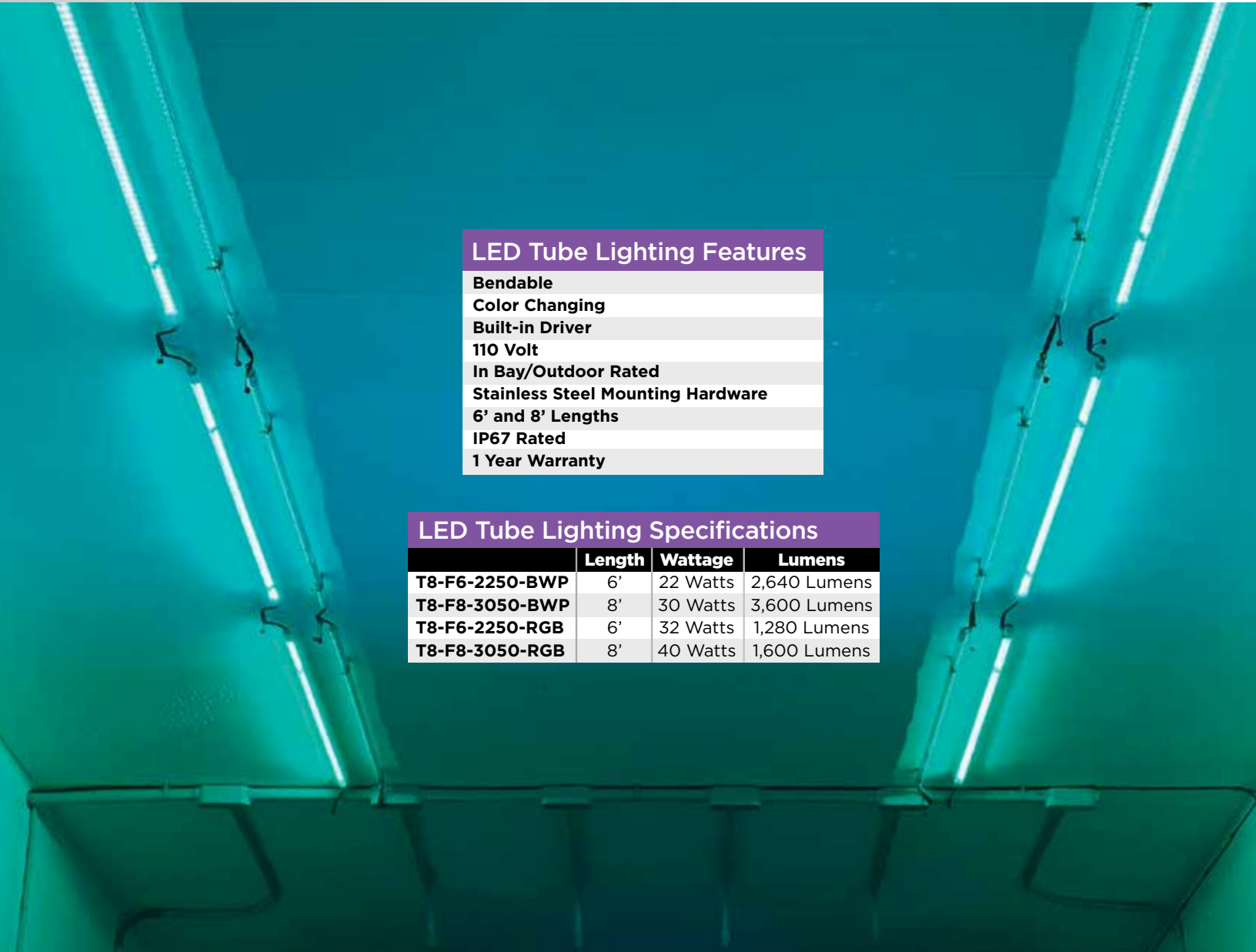

### LED Tube Lighting Features

- Bendable**
- Color Changing**
- Built-in Driver**
- 110 Volt**
- In Bay/Outdoor Rated**
- Stainless Steel Mounting Hardware**
- 6' and 8' Lengths**
- IP67 Rated**
- 1 Year Warranty**

### LED Tube Lighting Specifications

	Length	Wattage	Lumens
<b>T8-F6-2250-BWP</b>	6'	22 Watts	2,640 Lumens
<b>T8-F8-3050-BWP</b>	8'	30 Watts	3,600 Lumens
<b>T8-F6-2250-RGB</b>	6'	32 Watts	1,280 Lumens
<b>T8-F8-3050-RGB</b>	8'	40 Watts	1,600 Lumens



The Premier LED App allows complete access to lighting controls from your phone, tablet or computer.

Control multiple locations and make changes while off-site with ease using the Premier Hub,

Premier Tube Lighting is bendable and built to preform in the harshest conditions. Made to be in bay as well as outdoors, these lights create an eye-popping focal point for your facilities and outdoor canopy systems.



# LED Lighting



COLOR CHANGING  
POWERED BY THE  
PREMIER APP!

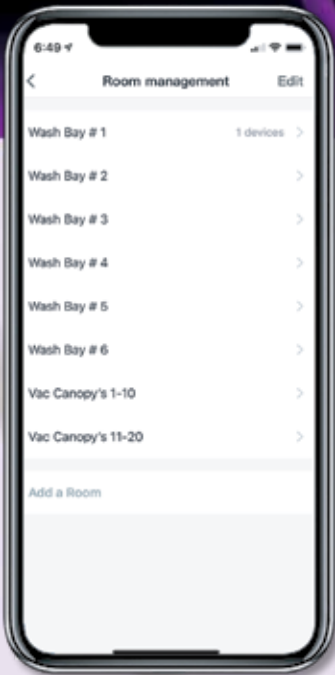

ROOM  
MANAGEMENT  
CONTROLLED BY  
THE APP





ADD PUCKS,  
SPINNERS OR  
DOTS FOR ADDED  
IMPACT!

## Arches and Overheads

These days, a car wash is about more than just a clean car. It's about providing your customers with a unique experience that makes a big impact. Our line of LED arches and overheads are sure to do just that. All of our signs are 120 volt, and are fully customizable with pucks, dots or spinners.

Our team of graphic designers are ready to create a standout arch that elevates our customer's brand. Creative designs and fast turnaround times, paired with the quality you've come to expect from Premier, turns a cruise through a wash into an illuminated adventure all can enjoy. Choose from our lineup of standard arches, or contact us for a one-of-a-kind custom design.

### Premier Arch





## Add Light Effect Options to Your Arch or Sign



### 4" LED Puck Lights

- Can be set to on, strobe or halo effect
- Available in green, blue, yellow, red and white



### 2" LED Spinners

- Available in green, blue, yellow, red, white and pink



### 1" Dot Light

- Available in white

### Flashers and Sequence Flashers



## Badge Arch



## Shield Arch





### 3 Piece Arch



### 5 Piece Arch



### Rain Drop Arch

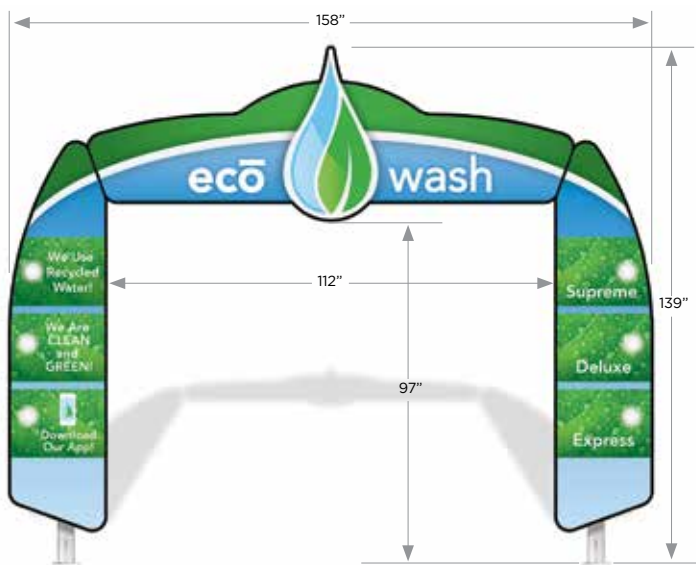

### Light Effects Arch

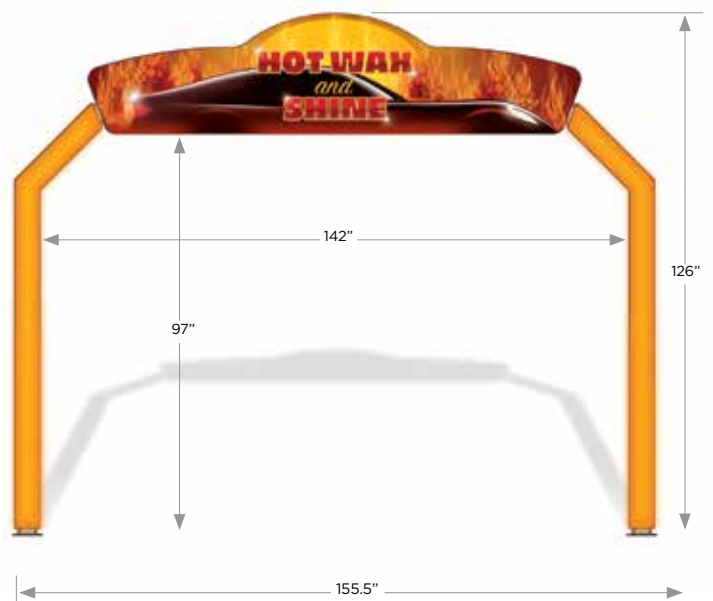



## Menu and Menu Boards



## Sectional Menus

- 3-6 Sections Available
- 33" Wide x 96" High
- HDPE Color Options Include Red, Blue, Black, Granite Gray, Green and Yellow
- Custom Powder Coated Pedestal Available
- 120 Volt
- Aluminum Construction



## Menu Boards

- Many Sizes Available
- Metal Color Options Include Red, Blue, Yellow, White and Black
- 120 Volt
- Aluminum Construction



# Pay Station Canopies



## Double Leg Canopy

- Shown With Laser Cut “Pay Here” and Lit Roto-Molded “Clearance” Signs
- Roof Live Load: 40 psf
- Basic Wind Speed: 130 mph



## Arch Canopy Top

- Shown With LED Lit “Pay Here” and Lit Roto-Molded “Clearance” Signs
- Roof Live Load: 40 psf
- Basic Wind Speed: 130 mph

### Features

- Double coated powder coating process with a zinc primer base and colored second coat
- Powder coated extruded aluminum top without ridges to eliminate debris buildup and nesting
- Laser-cut holes in post for neat and efficient electrical installation
- Footing covers for a clean look

### Lighting Options

- (1) 4’ 5K LED included
- RGB upgrade available
- Jumper cables and off-site controls available with the Premier Hub

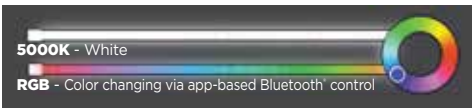

### Included

- Laser-cut “Pay Here” sign
- (1) 4’ 5K LED

### Color Options

- Blue, black, red, green or yellow
- Custom colors available by request

### Optional Upgrades

- Additional LED lighting
- J-anchor template kit
- Lit “Pay Here” sign
- Lit “Clearance” sign
- Customizable artwork to meet your customer’s expectations and brand



### LED Sign Lit Options



### Unlit Sign Options







## Wall Mount & Pedestal Sectionals

- 2 - 8 sections available
- All signs are 120 Volt
- Dual pivot stainless steel arms for adjustability
- LED puck color options: red, white, blue, yellow and green
- HDPE color options: red, blue, black, granite gray, green and yellow
- Powder coat color options: red, blue, black, yellow and white
- Stainless steel construction



## Roto-Molded Signs

- All signs are 120 Volt
- HDPE color options: red, blue, black, granite gray, green and yellow
- Powder coat options: red, blue, black, yellow and white
- Stainless steel construction



## Tunnel/Wall & Channel Letters

- HDPE and aluminum housings available
- LED spinner light color options: red, blue, green, yellow, pink and white
- Stainless steel construction



- 24" round or square



- 24", 30" and 36" letters available

## Clearance



- Clearance Cross Bars • Custom designs and colors available
- Clearance Structures • Custom designs and colors available



- Roto-Molded Lit "Clearance" Signs
- Custom designs and colors available
- Unlit "Clearance" Signs
- Custom designs and colors available

Your Manufacturing Partner



VISIT US ONLINE



2210 Heldt Street  
Merrill, WI 54452  
866.539.3100  
sales@precisionlaser cutting.com  
premiercompaniesusa.com

